

RT3 BRAKE CALIPER INSTALLATION GUIDE

DISCLAIMER: Kraus Motor Co. recommends that you defer to a certified mechanic or technician on any installation when possible. Refer to your OEM service manual for procedure, step by step procedures, required tools and specifications to make sure all pieces and parts are properly installed. Kraus Motor Co. is not responsible for improper installation of any OEM or Kraus component/kit. After completing installation, go for a slow, careful test ride. Afterwards, double check all pieces, parts and systems. Improper installation may result in severe injury or death.

BEFORE INSTALLATION:

- O1 RT3 Brake Calipers should be installed by an experienced professional. Brakes are the most important component in slowing a motorcycle to a controllable state, if any concern or doubts occur during installation, please visit your local dealer.
- O2 Calipers must be bled.
- O3 Bedding in pads is required.

BEGIN INSTALLATION:

- O1 Ensure all components have shipped with caliper.

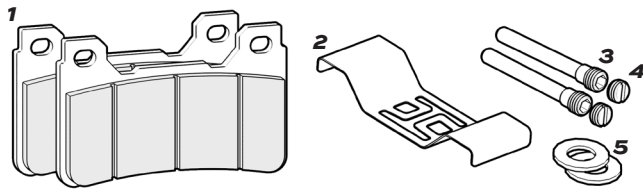

INCLUDED COMPONENTS
1) Brake Pad x2
2) Spring Clip x1
3) Pin x2
4) Retaining Nut x2
5) Crush Washer x2

- O2 Install pads in caliper with spring clip. Pins are tightened snugly with retaining nut installed.
- O3 Orient caliper correctly to 108mm mount: (Caliper should have banjo in highest position for easiest bleeding process)

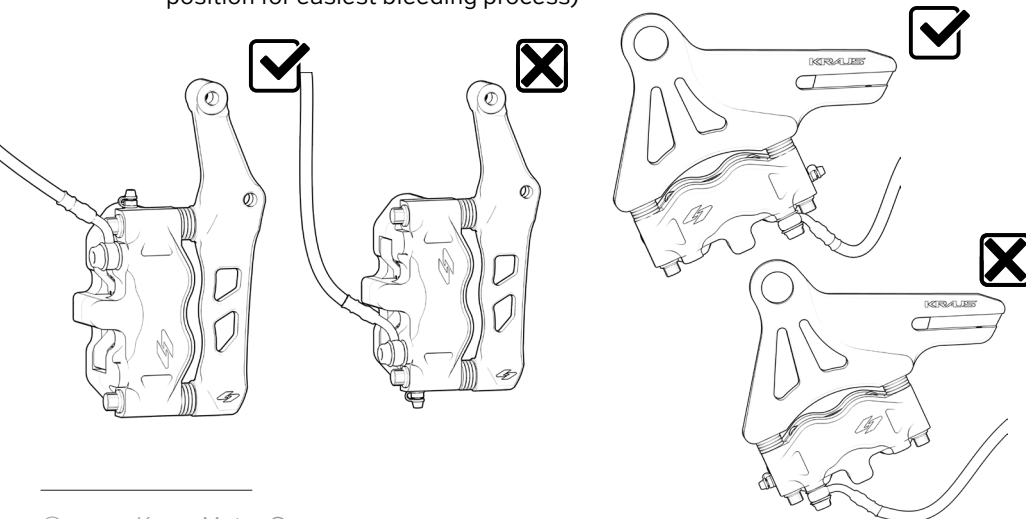

- O4 RT3 Brake Calipers are designed to fit mounts with 108mm center to center M10 bolt holes. This includes Axial to Radial, KR8, SX5, Dynamoto Radial Mount, and Rear Radial Mount.
- O5 If using radial spacers, loosely thread M10 hardware and begin fitting spacers for best fit.

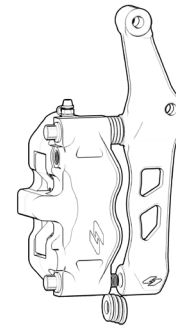

- O6 Station the pad within the inside edge of the rotor. The rotor should not contact the internal components of the caliper.

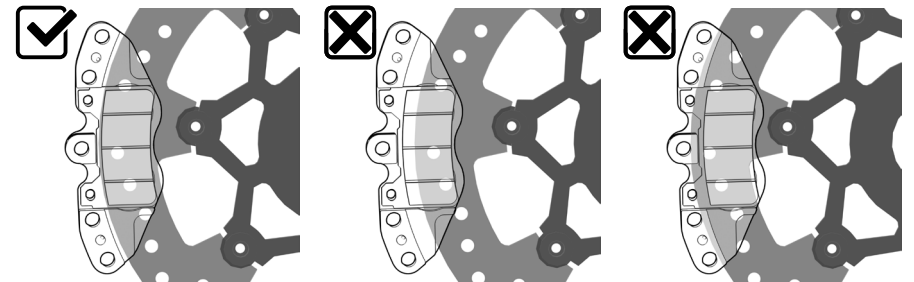

- O7 With caliper spacers configured and orientation set, dry fit the brakeline to ensure proper length and appropriate flexibility.
- *** **NOTE:** Lines should not be pinched or stretched, or be limited by steering or suspension travel.
- *** **TECH TIP:** Head of spiegler brakelines have indentations allowing for head rotation

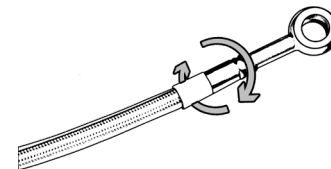

RT3 BRAKE CALIPER INSTALLATION GUIDE (CONT.)

08 With lines properly routed, banjo bolt and caliper bolts can be installed and torque'd.

*** **NOTE: Loctite 243 is recommended for caliper mounting bolts.**

TORQUE SPECS:	Kraus Titanium Hardware	-	38 ft-lbs
	ARP Hardware	-	38 ft-lbs
	Stainless Steel	-	24 ft-lbs

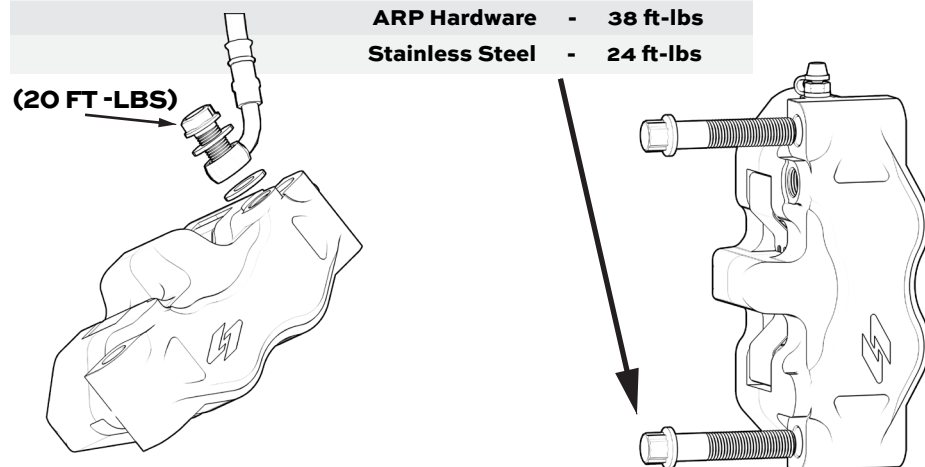

CALIPERS MUST BE BLED

01 Kraus calipers have been pre-bled for an easier and quicker bleeding process. However, air can still exist from shipping and installation of new brake lines. DO NOT operate motorcycles without a firm brake lever and/or pedal.

*** **TECH TIP: For an easier bleeding process, connect and torque lines with fluid dripping from line.**

*** **IMPORTANT: BRAKE FLUID CAN REMOVE PAINT. Tape/cover areas of concern and ensure fluid does not entirely drain from master cylinder.**

BEDDING IN PADS

01 After the calipers are bled, the motorcycle can be operated. Fresh brake pads will have a dissimilar surface for less optimal braking for several stops until the calipers have heated and adjusted to surface of the rotor. Extra caution should be taken when slowing down. Calipers will have a noticeable improvement in performance when these conditions have been met.

ENJOY THE RIDE!

Check back after riding to confirm there are no visible leaks or issues.